

P43-G4V-2G-002-400E | Page 1

Ultrasonic Distance Sensor / Ultraschall Abstandssensor / Capteurs Ultrasoniques

Technical Data	Technische Daten	Données techniques	
Max. sensing distance	Max. Reichweite	Portée	200mm
Min. sensing distance	Min. Reichweite	Distance minimale	25mm
Beam angle	Schallkegelöffnung	Angle du faisceau	8 °
Alignment LED	Ausrichthilfe LED	DEL à l'alignement	Ja /
Switching outputs	Schaltausgänge	Sortie à seuil	1
Output circuit	Ausgangsschaltung	Circuit de sortie	NPN
Switching characteristics	Schaltcharakteristik	Caractéristique du seuil	NO / NC
Max. switching current	Max. Ausgangsstrom	Max. courant du sortie	100 mA
Switching frequency	Schaltfrequenz	Frequence de commutation	25 Hz
Repeatability	Wiederholgenauigkeit	Répétabilité	0,30%
Hysteresis	Hysterese	Hystérésis	2 %
Switching indication LED	LED Schaltanzeige	Indication Seuil DEL	Ja /
Set point adjustment	Einstellung Schaltpunkte	Réglage position seuil	Teach-In / Teac
Resolution	Auflösung	Resolution	0,25 mm
Temperature range	Temperaturbereich	Température service	-20 - +70 °C
Range of temperature compensation	Bereich der Temperaturkompensation	Gamme compensation température	-20 - 70 °C
Operating voltage	Spannungsbereich	Tension de service	10 - 30V
Current consumption without load	Stromverbrauch ohne Last	Courant consommé sans charge	<25 mA
Reverse polarity	Verpolung	Inversion de polarité	Ja / Yes / Oui
Voltage spikes on supply lines	Spannungsspitzen	Transitoires sur alimentation et sortie	Ja / Yes / Oui
Short circuit switching output	Kurzschluß	Courts-circuits sur sortie à seuils	Ja / Yes / Oui
Sealing	Schutzart	Degré de protection	IP65IP
Material of housing	Gehäusematerial	Material boîtier	Edelstahl / Stainless steel / Acier inox
Dimensions	Abmessungen	Dimensions	M12x1x79
Wiring	Anschluß	Connection	Stecker M12 / Connec

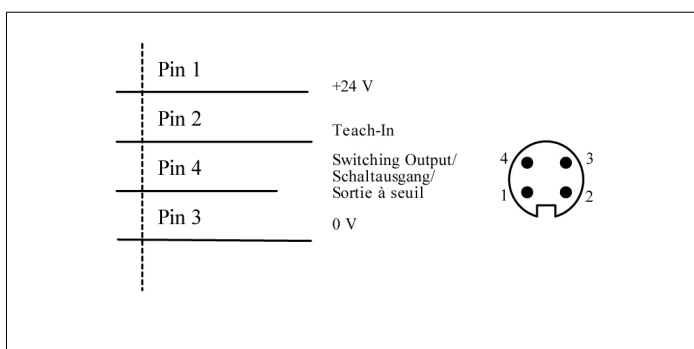
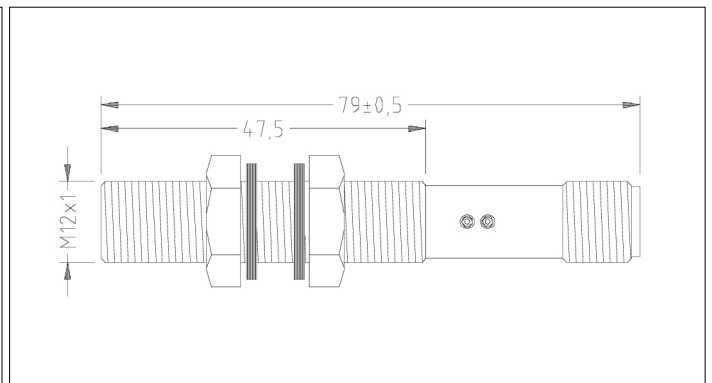
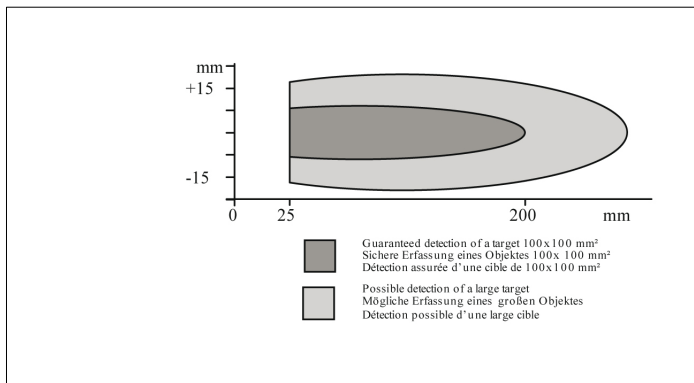

<p>Normal function: Yellow LED is indicating status of the switching output. Green LED indicates receiving of an Echo. (Alignment assistance)</p>	<p>Normale Funktion: Gelbe LED zeigt Schaltzustand das Ausgangs an. Grüne LED zeigt an, wenn ein Echo empfangen wird. (Ausrichthilfe)</p>	<p>Fonctionnement normal du capteur: DEL jaune indique l'état du sortie à seuil. DEL verte sera allumé si un écho est reçu. Il s'agit d'un témoin d'alignement.</p>
---	---	---

<p>1 Teach is switching output NC at distance P1 as discribed in A 2 Teach in P2: Connect teach in line with GND (0V) around 16 sec. First after ~8 sec. yellow LED is blinking with ~2 Hz, after additional 8 sec. yellow LED is blinking with 2 Hz. Disconnect teach in line: sensor is now in teach in mode for P2: yellow LED is blinking with ½ Hz. Position object in Position of P2. When yellow LED on: connect each in line with GND (0V) and disconnect. Sensor is now programmed.</p>	<p>1 Einlernen des Schaltpunktes NC am Abstand P1 wie unter A beschrieben. 2 Einlernen P2: Verbinden Sie den Teach-In Eingang mit GND (0V) ca. 16 sec. Zunächst -nach ca. 8 sec.- blinkt gelbe LED mit ~2 Hz, nach weiteren 8 sec. blinkt sie mit 2 Hz Verbindung trennen: jetzt ist Sensor im Tech In Modus: gelbe LED blinkt mit ~ ½ Hz. Objekt an gewünschten Fensterrand P2 bringen Wenn gelbe LED an: Teach-In Eingang kurz mit GND (0V) verbinden und wieder trennen. Der Sensor ist jetzt wie gewünscht programmiert</p>	<p>1. Apprentissage de la sortie à seuil NC a la distance P1 (décrit à A). 2. Apprentissage P2: Connecter la sortie apprentissage avec GND (0V) environ 16 sec. D'abord -après ~8 sec- DEL jaune clignote ~2 Hz et après encore 8 sec. DEL jaune clignote ~ 1 Hz. Déconnecter la sortie apprentissage: le capteur est maintenant en mode 'programmation pour P2: DEL jaune clignote ~ ½ Hz. Placer l'objet à la nouvelle position désirée de P2. Si DEL jaune est allumé: Connecter et déconnecter la sortie apprentissage la masse GND (0V). Le capteur est programmé</p>
--	--	---

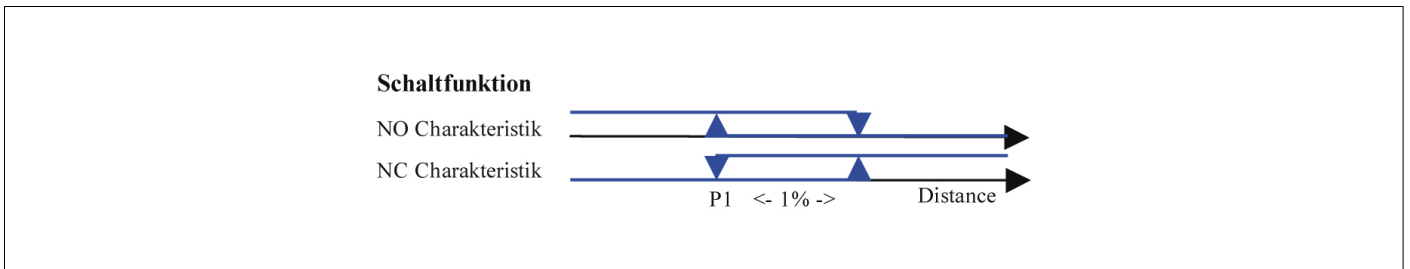

<p>1 Teach is switching output NC at distance P1 as discribed in A 2 Teach in P2: Connect teach in line with GND (0V) around 16 sec. First after ~8 sec. yellow LED is blinking with ~2 Hz, after additional 8 sec: yellow LED is blinking with 1 Hz. Disconnect teach in line: sensor is now in teach in mode for P2, yellow LED is blinking with ½ Hz. Position object in Position of P2. When yellow LED off: connect each in line with GND (0V) and disconnect. Sensor is now programmed.</p>	<p>1 Einlernen des Schaltpunktes NC am Abstand P1 wie unter A beschrieben. 2 Einlernen P2: Verbinden Sie den Teach-In Eingang mit GND (0V) ca. 16 sec. Zunächst -nach ca. 8 sec.- blinkt gelbe LED mit ~2 Hz, nach weiteren 8 sec. blinkt gelbe LED mit 1 Hz Verbindung trennen: jetzt ist Sensor im Tech In Modus: gelbe LED blinkt mit ~ ½ Hz. Objekt an gewünschten Hysterese-Schaltabstand P2 bringen Wenn gelbe LED aus: Teach-In Eingang kurz mit GND (0V) verbinden und wieder trennen. Der Sensor ist jetzt wie gewünscht programmiert</p>	<p>1. Apprentissage de la sortie à seuil NC a la distance P1 (décrit à A). 2. Apprentissage P2 Connecter la sortie apprentissage avec GND (0V) environ 16 sec. D'abord -après ~8 sec- DEL jaune clignote ~ 2 Hz et après encore 8 sec. DEL jaune clignote ~ 1 Hz. Déconnecter la sortie apprentissage: le capteur est maintenant en mode 'programmation pour P2 : DEL jaune clignote ~ ½ Hz. Placer l'objet à la nouvelle position désirée de P2. Si DEL jaune est éteint: Connecter et déconnecter la sortie apprentissage la masse GND (0V). Le capteur est programmé</p>
--	---	--

<p>1 Teach is switching output NO at distance P1 as discribed in A 2 Teach in P2: Connect teach in line with GND (0V) around 16 sec. First after ~8 sec. yellow LED is blinking with ~2 Hz, after additional 8 sec. Yellow LED is blinking with 1 Hz. Disconnect teach in line: sensor is now in teach in mode for P2: yellow LED is blinking with ~ 1/2 Hz. Position object in Position of P2. When yellow LED on: connect each in line with GND (0V) and disconnect. Sensor is now programmed.</p>	<p>1 Einlernen des Schaltpunktes NO am Abstand P1 wie unter A beschrieben. 2 Einlernen P2: Verbinden Sie den Teach-In Eingang mit GND (0V) ca. 16 sec. Zunächst -nach ca. 8 sec.- blinkt gelbe LED mit ~2 Hz, nach weiteren 8 sec. blinkt gelbe LED mit 1 Hz Verbindung trennen: jetzt ist Sensor im Tech In Modus für P2: gelbe LED blinkt mit ~ 1/2 Hz. Objekt an gewünschten Hysterese-Schaltabstand P2 bringen Wenn gelbe LED an: Teach-In Eingang kurz mit GND (0V) verbinden und wieder trennen. Der Sensor ist jetzt wie gewünscht programmiert</p>	<p>1. Apprentissage de la sortie à seuil NO a la distance P1 (décrit à A). 2. Apprentissage P2 : Connecter la sortie apprentissage avec GND (0V) environ 16 sec. D'abord -après ~8 sec- DEL jaune clignote ~2 Hz et après encore 8 sec. DEL jaune clignote ~ 1 Hz. Déconnecter la sortie apprentissage: le capteur est maintenant en mode 'programmation pour P2: DEL jaune clignote ~ 1/2 Hz. Placer l'objet à la nouvelle position désirée de P2. Si DEL jaune est allumé: Connecter et déconnecter la sortie apprentissage la masse GND (0V). Le capteur est programmé.</p>
--	--	--

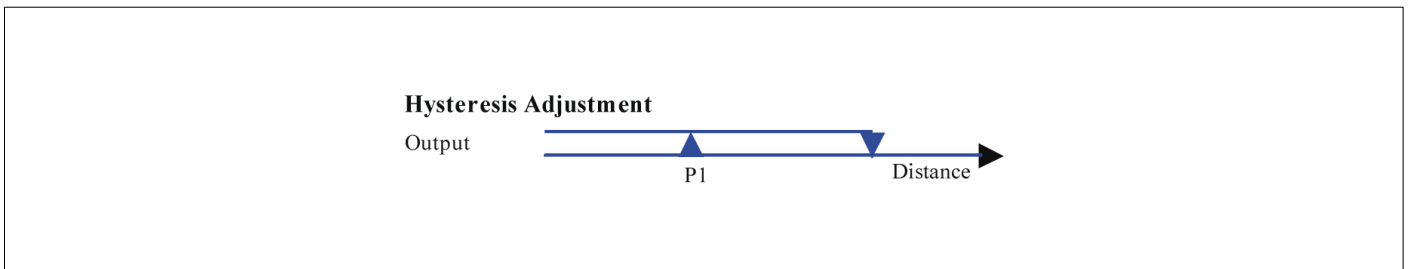

<p>1 Teach is switching output NO at distance P1 as discribed in A 2 Teach in P2: Connect teach in line with GND (0V) around 16 sec. First after ~8 sec. yellow LED is blinking with ~2 Hz, after additional 8 sec. Yellow LED is blinking with 1 Hz. Disconnect teach in line: sensor is now in teach in mode for P2: yellow LED is blinking with 1/2 Hz. Position object in Position of P2. When yellow LED off: connect each in line with GND (0V) and disconnect. Sensor is now programmed.</p>	<p>1 Einlernen des Schaltpunktes NO am Abstand P1 wie unter A beschrieben. 2 Einlernen P2: Verbinden Sie den Teach-In Eingang mit GND (0V) ca. 16 sec. Zunächst -nach ca. 8 sec. - gelbe LED mit ~2 Hz, nach weiteren 8 sec. blinkt sie mit 1 Hz Verbindung trennen: jetzt ist Sensor im Teach In Modus: gelbe LED blinkt mit ~ 1Hz. Objekt an gewünschten Fensterrand P2 bringen Wenn gelbe LED aus: Teach-In Eingang kurz mit GND (0V) verbinden und wieder trennen. Der Sensor ist jetzt wie gewünscht programmiert</p>	<p>1. Apprentissage de la sortie à seuil NO a la distance P1 (décrit à A). 2. Apprentissage P2 : Connecter la sortie apprentissage avec GND (0V) environ 16 sec. D'abord -après ~8 sec- DEL jaune clignote ~2 Hz et après encore 8 sec. DEL jaune clignote ~ 1 Hz. Déconnecter la sortie apprentissage: le capteur est maintenant en mode 'programmation pour P2: DEL jaune clignote ~ 1/2 Hz. Placer l'objet à la nouvelle position désirée de P2. Si DEL jaune est éteint: Connecter et déconnecter la sortie apprentissage la masse GND (0V). Le capteur est programmé</p>
--	---	---

<p>Connect Teach In line with GND (0V) ~8 sec until yellow LED P1 starts blinking ~ 2Hz. Disconnect: sensor now in teach-in mode: Yellow LED P1 is now blinking ~ ½ Hz. Within 35 sec. set point has to be set. Position object to desired switching position P1. Connect and disconnect teach-in line with GND (0V). Switching output is teached. P2 is 1% farer from the sensor than P1. Switching characteristic NO/NC Is yellow LED P1 (#4) is on during teach-in setting, Sensor has NO characteristic, is it off, Sensor has NC characteristic. Sensor is now operating in normal function.</p>	<p>Verbinden Sie den Teach-In Eingang mit GND (0V) ca. 8 sec. bis gelbe LED P1 mit ~2 Hz blinkt. Verbindung trennen: jetzt ist Sensor im Teach In Modus: gelbe LED P1 blinkt mit ~ ½ Hz. Innerhalb von 35 sec. muss der Schalterpunkt eingelernt werden! Objekt an gewünschten Schaltabstand P1 bringen Teach-In Eingang kurz mit GND (0V) verbinden und wieder trennen. Der Schalterpunkt ist eingelernt. P2 liegt 1% weiter vom Sensor entfernt Schaltcharakteristik NO/NC Ist beim Einlernen des Schalterpunktes die LED P1 (#4) an, so hat der Schalterpunkt NO Charakteristik, ist sie aus, so ist die Charakteristik NC. Sensor arbeitet jetzt in normaler Funktion mit neuem eingestellten Wert.</p>	<p>Connecter la sortie apprentissage avec GND (0V) environ 8 sec. jusqu'à clignotement DEL P1 jaune a une fréquence de ~ 2 Hz. Déconnecter la sortie apprentissage: le capteur est maintenant en mode 'programmation pour P1: DEL P1 jaune clignote a une fréquence de ~ ½ Hz. A ce moment, une séquence de 35 sec. commence pour effectuer la programmation de la position P1 Placer l'objet à la nouvelle position désirée de P1. Connecter et déconnecter la sortie apprentissage a la masse GND (0V) P1 est maintenant programmé. P2 se trouve a une position 1% plus grande que P1 avant le capteur. Choix entre sortie NO / NF Si pendant la procédure apprentissage de P1 (#4) DEL P1 jaune est allumé sortie est NO, lorsque DEL P1 est éteint sortie est NF. Le capteur retourne après la procédure finie en fonction normale avec la nouvelle valeur.</p>
---	---	---

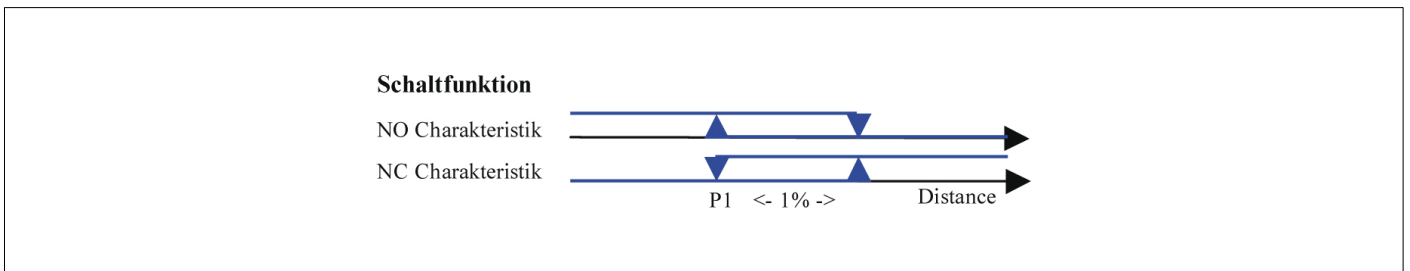

Detection range	Erfassungsbereich	Plage de détection mm
E Windows function NC switching characteristics	E Fensterfunktion NC Schaltcharakteristik	E Fonction fenêtre caractéristique NC

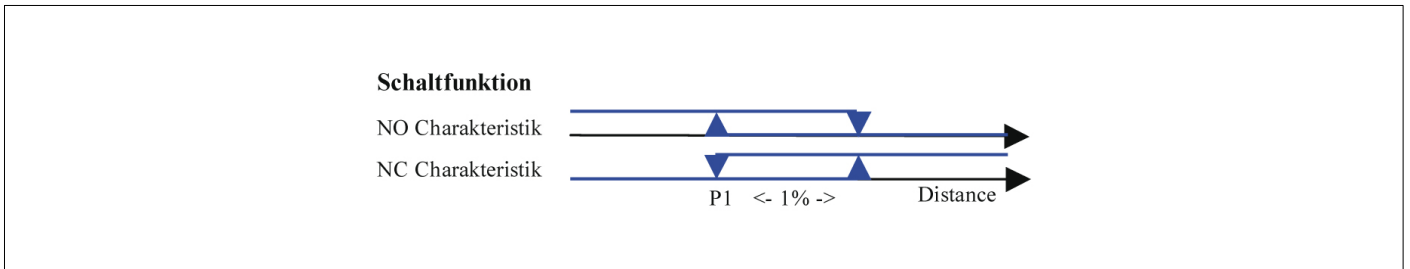

<p>1 Teach is switching output NC at distance P1 as discribed in A</p> <p>2 Teach in P2: Connect teach in line with GND (0V) around 16 sec. First after ~8 sec. yellow LED is blinking with ~2 Hz, after additional 8 sec. yellow LED is blinking with 2 Hz.</p> <p>Disconnect teach in line: sensor is now in teach in mode for P2: yellow LED is blinking with ½ Hz.</p> <p>Position object in Position of P2.</p> <p>When yellow LED on: connect each in line with GND (0V) and disconnect. Sensor is now programmed.</p>	<p>1 Einlernen des Schaltpunktes NC am Abstand P1 wie unter A beschrieben.</p> <p>2 Einlernen P2: Verbinden Sie den Teach-In Eingang mit GND (0V) ca. 16 sec. Zunächst -nach ca. 8 sec.- blinkt gelbe LED mit ~2 Hz, nach weiteren 8 sec. blinkt sie mit 2 Hz Verbindung trennen: jetzt ist Sensor im Tech In Modus: gelbe LED blinkt mit ~ ½ Hz. Objekt an gewünschten Fensterrand P2 bringen</p> <p>Wenn gelbe LED an: Teach-In Eingang kurz mit GND (0V) verbinden und wieder trennen. Der Sensor ist jetzt wie gewünscht programmiert</p>	<p>1. Apprentissage de la sortie à seuil NC a la distance P1 (décrit à A).</p> <p>2. Apprentissage P2: Connecter la sortie apprentissage avec GND (0V) environ 16 sec. D'abord -après ~8 sec- DEL jaune clignote ~2 Hz et après encore 8 sec. DEL jaune clignote ~ 1 Hz.</p> <p>Déconnecter la sortie apprentissage: le capteur est maintenant en mode 'programmation pour P2: DEL jaune clignote ~ ½ Hz. Placer l'objet à la nouvelle position désirée de P2.</p> <p>Si DEL jaune est allumé: Connecter et déconnecter la sortie apprentissage la masse GND (0V). Le capteur est programmé</p>
--	---	---

<p>1 Teach is switching output NC at distance P1 as discribed in A</p> <p>2 Teach in P2: Connect teach in line with GND (0V) around 16 sec. First after ~8 sec. yellow LED is blinking with ~2 Hz, after additional 8 sec: yellow LED is blinking with 1 Hz.</p> <p>Disconnect teach in line: sensor is now in teach in mode for P2, yellow LED is blinking with ½ Hz. Position object in Position of P2.</p> <p>When yellow LED off: connect each in line with GND (0V) and disconnect. Sensor is now programmed.</p>	<p>1 Einlernen des Schaltpunktes NC am Abstand P1 wie unter A beschrieben.</p> <p>2 Einlernen P2: Verbinden Sie den Teach-In Eingang mit GND (0V) ca. 16 sec. Zunächst -nach ca. 8 sec.- blinkt gelbe LED mit ~2 Hz, nach weiteren 8 sec. blinkt gelbe LED mit 1 Hz</p> <p>Verbindung trennen: jetzt ist Sensor im Tech In Modus: gelbe LED blinkt mit ~ ½ Hz. Objekt an gewünschten Hysterese-Schaltabstand P2 bringen</p> <p>Wenn gelbe LED aus: Teach-In Eingang kurz mit GND (0V) verbinden und wieder trennen. Der Sensor ist jetzt wie gewünscht programmiert</p>	<p>1. Apprentissage de la sortie à seuil NC a la distance P1 (décrit à A).</p> <p>2. Apprentissage P2</p> <p>Connecter la sortie apprentissage avec GND (0V) environ 16 sec. D'abord -après ~8 sec- DEL jaune clignote ~ 2 Hz et après encore 8 sec. DEL jaune clignote ~ 1 Hz.</p> <p>Déconnecter la sortie apprentissage: le capteur est maintenant en mode 'programmation pour P2 : DEL jaune clignote ~ ½ Hz.</p> <p>Placer l'objet à la nouvelle position désirée de P2.</p> <p>Si DEL jaune est éteint: Connecter et déconnecter la sortie apprentissage la masse GND (0V). Le capteur est programmé</p>
--	---	--

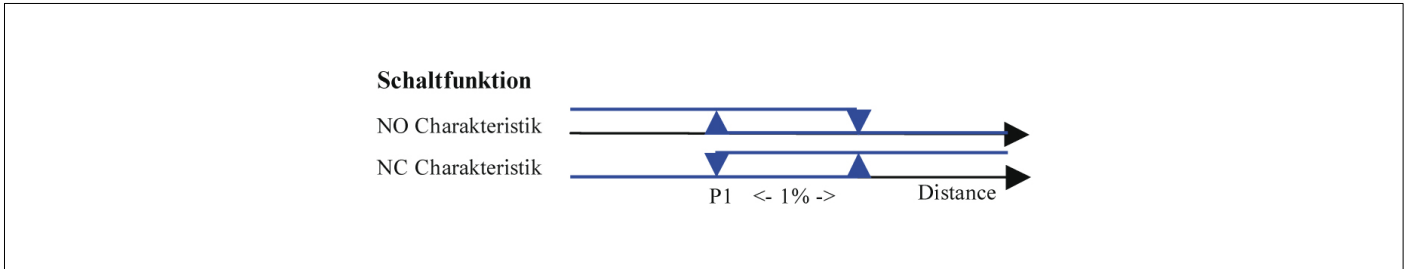

!!! WARNING !!! PERSONAL INJURY	!!! WARNUNG !!! PERSONENSCHADEN	!!! ATTENTION !!! BLESSURES COPORELLES
DO NOT USE these products as safety or emergency stop devices, or in any other application where failure of the product could result in personal injury. Failure to comply with these instructions could result in death or serious injury.	Diese Produkte dürfen weder als Sicherheits- oder Not-Abschaltgeräte noch in anderen Anwendungen, bei denen ein Fehler an diesem Produkt zu Personenschaden führen könnte, eingesetzt werden. Missachtung dieser Anweisungen kann zu schweren Verletzungen oder zum Tod führen.	NE PAS UTILISER ces produits en tant que dispositifs d'arrêt d'urgence ou de sécurité, ni dans aucune autre application où la défaillance du produit pourrait entraîner des blessures corporelles. L'observation de ces instructions peut entraîner la mort ou de graves blessures.

Warranty/Remedy	Garantie und Haftungsansprüche	Garantie/ Recours
PiL warrants goods of its manufacture as being free of defective materials and faulty workmanship. If warranted goods are returned to PiL during the period of coverage, PiL will repair or replace without charge those items it finds defective. The foregoing is Buyer's sole remedy and is in lieu of all other warranties, expressed or implied, including those of merchantability and fitness for a particular purpose. Specifications may change without notice. The information we supply is believed to be accurate and reliable as of this printing. However we assume no responsibility for its use. While we provide application assistance personally, through our literature and the PiL web site, it is up to the customer to determine the suitability of the product in the application.	PiL garantiert für seine hergestellten Produkte fehlerfreies Material und Qualitätsarbeit. Wenn Produkte innerhalb der Gewährleistungsfrist an PiL zurückgesendet werden, ersetzt oder repariert PiL kostenlos die Teile, die als fehlerhaft angesehen werden. Das Vorangegangene gilt als einzige Entschädigung des Käufers und alle anderen ausdrücklichen oder stillschweigenden Garantien einschließlich Qualitäts- und Sachmängelhaftung. Änderungen der technischen Daten ohne Vorankündigung sind vorbehalten. Die von uns bereitgestellten Informationen halten wir für exakt und zuverlässig, wie bei dieser Druckschrift. Wir übernehmen jedoch keine Haftung für deren Anwendung. Obwohl PiL persönliche und schriftliche Anwendungshilfe sowie Informationen über die PiL Webseite bietet, ist es die Entscheidung des Kunden ob das Produkt sich für die entsprechende Anwendung eignet.	PiL garantit que les articles de sa fabrication sont exempts de défaut de pièces et main d'oeuvre. Si les articles garantis sont retournés à PiL pendant la période de couverture, PiL réparera ou remplacera gratuitement ceux qui auront été trouvés défectueux. Ce qui précède constitue le seul recours de l'acheteur et se substitue à toutes autres garanties explicites ou implicites, y compris celles relatives à la commercialisation ou la compatibilité avec une application particulière. Les caractéristiques techniques peuvent changer sans préavis. Les informations que nous apportons sont présumées précises et fiables au moment de la mise sous presse. Cependant, nous déclinons toute responsabilité quant à leur utilisation. Bien que nous apportons notre aide pour les applications, de façon individuelle, par notre littérature et par le site web PiL, il incombe au client de déterminer si le produit convient à l'application.